

Measumax

OUTSIDE DIGIT MICROMETER

MODEL 11-100 - 11-1001

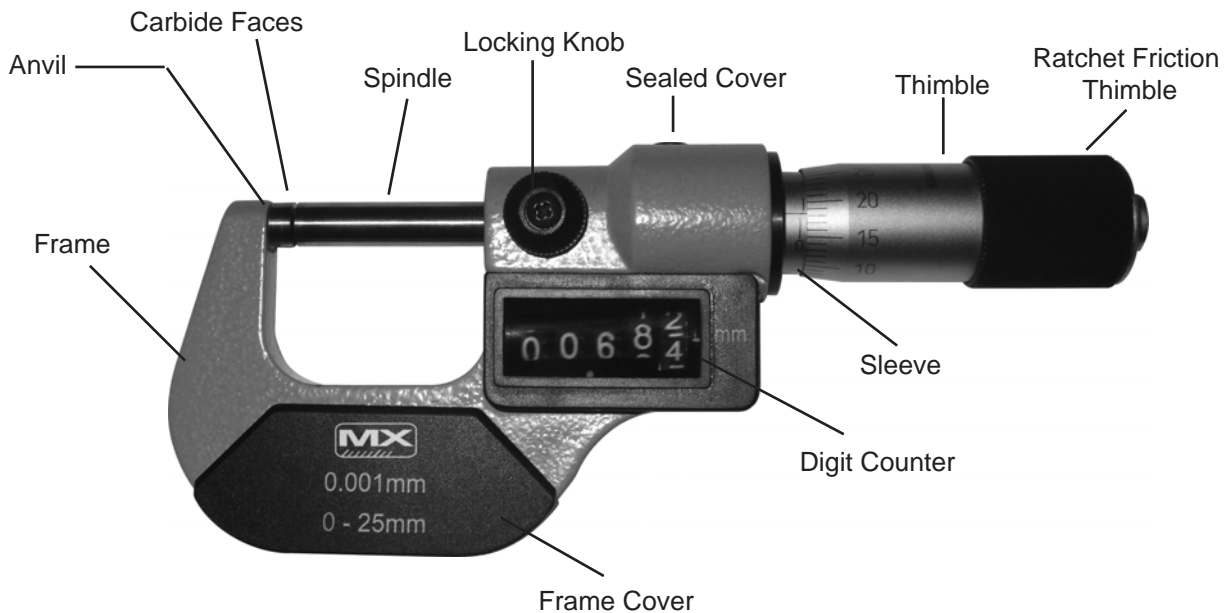

Reading Method

The Measumax Digit Micrometer has two ways of reading the measurement.

1. Graduations on the thimble and sleeve



2) Reading method of digit counter

a) The reading is taken in two parts. The first is the readings to the left of the decimal point and the second is the reading taken to the right of the decimal point. For example in Fig.4.3 the reading is 0.99995" or 9.9999mm as the numbers to the left of the decimal point have not yet completely rolled over. The reading in Fig. 4.4 is 0.0228" or 11.228mm. In Fig.4.5 the reading is 0.0170" or 11.170mm, and the reading is 0.0311" or 11.341mm in fig. 4.6.



Fig. 4.3

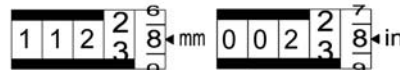

Fig. 4.4

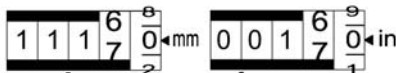

Fig. 4.5



Fig. 4.6

b) The reading in Fig. 4.7 is 0.9003" or 9.003mm and the reading is 0.5165" or 5.164mm in fig. 4.8.

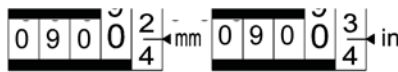

Fig. 4.7

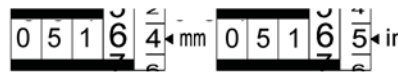

Fig. 4.8

5. Precautions

- Use ratchet stop to keep precision measuring.
- Do not disassemble and drop the instrument.
- Keep the instrument clean and dry.

OUTSIDE DIGIT MICROMETER

11-100 & 11-1001

When calibrating the micrometer please keep in mind that the Digit Counter reads to 1 micron. This usually requires the instrument to be set at a room temperature of 20 degrees C

Before attempting to set the Zero position on the micrometer clean the faces with a soft cloth to insure that any dirt has been removed and the faces are clean.

ZERO Setting for the 11-100 and 11-1001

1. Adjust the Zero position on the micrometer head using the spanner provided as Fig.1
2. Open the sealed cover (see Fig.2)
3. Rotate the thimble until the screw in the gear is visible.
4. Unlock the screw
5. Hold the gear with the key and rotate the thimble until the digit counter reads the same as the micrometer head
6. Lock the screw and close the sealed cover

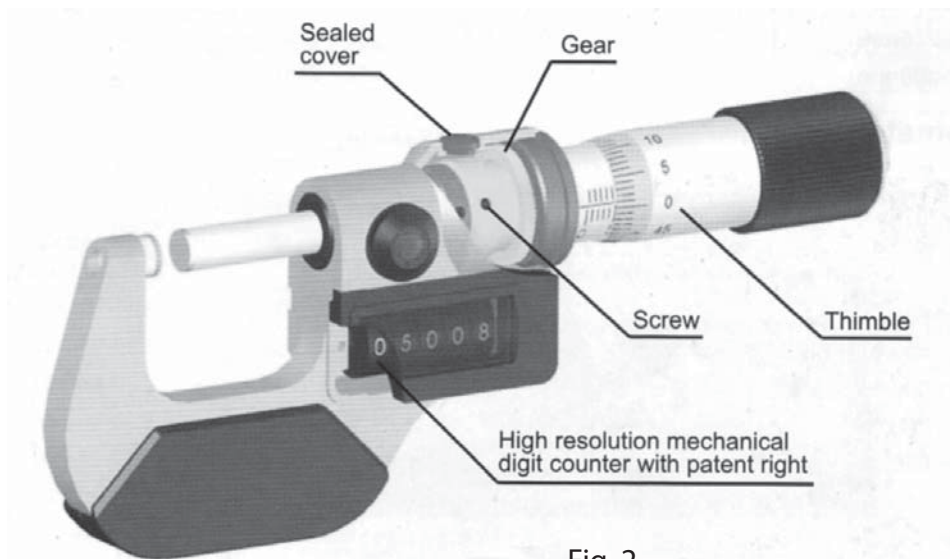
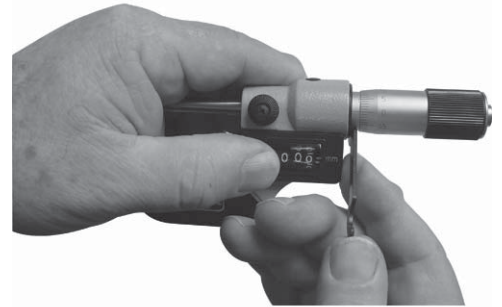

Fig. 2